

The Choke Rod

preserving and restoring the Model A Ford since 1956

Volume 60, Issue 8

Celebrating the Model A for Sixty Years

August 2016

San Francisco Bay Area Chapter

Model A Ford Club of America



Photo by Scott Williams

Ironstone Concours d'Elegance

tour details on page 3

Upcoming Tours

Sunday August 14- Barry's Magical Mystery Tour - Shhh! It's a Surprise!

Friday-Sunday, September 23-25 - Ironstone Concours d'Elegance - Murphys CA

Sunday October 9 - Italian Heritage Parade - San Francisco

Sunday November 13 - Veterans Day Parade - Fisherman's Wharf

Official Publication of the
San Francisco Bay Area Chapter
MAFCA

President's Message

OFFICERS

PRESIDENT

Barry Kinney

VICE PRESIDENTS

Tom Escher

Gunard Mahl

Greg Martinez

SECRETARY

Joan Peterson

TREASURER

Jeanine Mahl

PAST PRESIDENT

Gary Barrango

The Choke Rod is published once each month by the San Francisco Bay Area Chapter of the Model A Ford Club of America. It is mailed free to each member in good standing and mailed to other antique car clubs in exchange for their publications. The Choke Rod takes no responsibility for the accuracy of materials, dates, places, prices, etc of its contents. Permission to reproduce is hereby granted provided credit is given to The Choke Rod. The Choke Rod welcomes articles, art work, ideas, suggestions, etc.

Please submit any and all material to the editor by the last Monday of each month. Articles and photos may be submitted to: modela@pacbell.net or mailed to Walter Caplan at 157 Warren Drive, San Francisco, CA 94131.

TOUR CHAIR: Gary Barrango
EDITORS: Walter Caplan
Scott Williams
TECH EDITOR: Steve Owsley
MEMBERSHIP: Walter Caplan

The MIDWEST TRAIN TOUR is scheduled for September 5-18 of 2017. This tour will include fifteen historic sites and museums scattered across three states. Train reservations will need to be confirmed before the end of November. If you plan to go the planners will need to know by October. It is important that we all arrive in Dearborn Michigan on the same day. Tour schedules are available at our meetings or from our Editor.



IRONSTONE Concoors is on the horizon. We plan to caravan up to Murphys on Friday the 23rd of September. We will nail down the start time and meeting place by the August meeting. On Saturday night September 24th we have dinner reservations for twenty at the Historic Murphys Hotel. Dinner is at 6 pm in the banquet room.

THE MYSTERY TOUR is less of a mystery than it was a week ago. It will be different but unlikely to live up to its billing. We will meet at the parking lot of the Hiller Museum in San Carlos at 8:30 am on Sunday August 14 for a running board breakfast. We plan to depart the Hiller Museum at 9 am. The Museum is on the east side of Highway 101 near the San Carlos Airport. There is a big sign on the highway. NO - we are not going to the museum. There will be a Mystery Lunch. I will get a head count at the August meeting.

See you at the meeting,

Barry Kinney

The San Francisco Model "A" Ford Club encourages membership in MAFCA, the National Model "A" Ford Club. Benefits include an excellent bi-monthly publication, *The Restorer*, providing technical information and free liability insurance when participating in Club Events.

MAFCA

Model A Ford Club of America, Inc.
250 South Cypress Street
La Habra CA 90631
www.mafca.com
562-697-2712



MAFCA dues are \$40 per year. Dues for new members may be paid at any time. Dues paid between November 1 and December 31 are valid for the remainder of the year paid plus the following year. Along with your check send in your name, spouse's name and complete address. An optional \$10 initiation fee includes a club pin, decal, badge, windshield card and a back issue of "The Restorer" magazine. If you use Mastercard or Visa, include the expiration date and your signature. Membership includes a subscription to *The Restorer*.

Columbus Day Celebration 2016 Italian Heritage Parade Sunday October 9

San Francisco's 148th Annual Italian Heritage Parade on Sunday, October 9, as the City's oldest civic event and the nation's oldest Italian-American parade and community celebration, will wind its way from Fisherman's Wharf to North Beach. A San Francisco institution since it was established in 1868

Highlights include dozens of handcrafted parade floats featuring Bay Area businesses, community groups, and Italian organizations; local high school Italian clubs and marching bands; special appearances by "Christopher Columbus" and Queen Isabella and Her Court; festive open-air dining and Italian wine and food specials at North Beach restaurants lining the Parade route; performances by a variety of traditional Italian musicians and performance artists; and special appearances by Bay Area and Italian-American celebrities. The Columbus Day celebration is local, lots of fun, and puts a few dollars in our treasury. If you are interested in being part of our contingent, contact Gary Barrango at 650-572-1142 or 415-821-2628.

St. Anne of the Sunset Annual Parish Festival Car Show Saturday, October 29

The St. Anne Parish Festival will be held Friday, Saturday, and Sunday October 28, 29, 30. There will be Free Admission, Games, Raffle, Silent Auction, Entertainment, Food and Beverages. The festival will conclude with a pancake brunch on Sunday October 30.

Our own Casey Martinez is planning a car show to be held on Saturday October 29 - from 10 am until 2 pm. Cars will assemble on the south side of Irving Street between Fourteenth Avenue and Funston as early as 9 am. Casey says "I'm looking for nice cars - and I know you have one. Please come and show your car and help a good cause at the St. Anne's Parish Festival." Contact Casey directly if you are interested in displaying your nice car.

Tour Leader: Casey Martinez 415-725-2450

Refreshments at the July meeting were provided by
Joan Peterson

Jeanine Mahl
will provide refreshments
at the August meeting



Barry's Magical Mystery Tour Sunday August 14 Somewhere in the Bay Area

Once again Barry will surprise us with another magical mystery tour. We will meet at the parking lot of the Hiller Museum in San Carlos at 8:30 am on Sunday August 14 for a running board breakfast. We plan to depart the Hiller Museum at 9 am. The Museum is on the east side of Highway 101 near the San Carlos Airport. There is a big sign on the highway. NO - we are not going to the museum. There will be a Mystery Lunch.

Tour Leader: Barry Kinney 415-282-2789

Overnighter to Murphys Ironstone Concours d'Elegance Friday - Sunday, September 23 - 25

By popular demand, for a tenth year the Club is planning another fabulous weekend tour to the gold country with stops along the way, group dinners, and a fantastic car show on the beautifully landscaped grounds of the Ironstone Winery in Murphys.

A limited number of hotel rooms have been reserved by Barry Kinney for club members. If you reserve one of the Club rooms, you will be obligated for two nights. No exceptions. A group of us will caravan to Murphys on Friday Morning.

Tour Leader: Barry Kinney 415-282-2789



BIRTHDAYS & ANNIVERSARIES



Gunard Mahl	August 2
Gary Barrango	August 4
Nick Craig	August 7
Bob Craig, Jr.	August 8
Susan Bettencourt	August 8
Darryl Coe	August 14
Maria Asuncion Young	August 15
Bev Kling	August 16
Colleen Rosenblat	August 16
Zack Rosenblat	August 24
Tom Machado	August 27
Jack Green	August 31

Barry Kinney & Coragine Savio	August 9
Scott Williams & Tom Mullins	August 22
Gary & Cheryl Barrango	August 26
Dan & Tracy Bowermaster	August 27



Beachwear is a fascinating area to explore. Early in the era the wool bathing suit came into play, displaying varied colors and styles. As indicated in the illustration, a variety of styles were available with interesting accessories. Most popular was the beach coat, usually available in silk with an oriental flair. None of the shoes shown are the appropriate footwear for bathing. Rubber bathing shoes, often white, were worn to protect the feet. A rubber bathing cap, sometimes in a variety of colors was worn to keep the "bob" hairstyle in place as well as to keep it dry.



To accompany the bathing suit and enlarge the wardrobe, wide leg "beach" pajamas were very popular. They came in a variety of fabrics. Most popular was cotton because of the climate, however, silk, rayon and celanese made up a large part of the pajama fashion world. As the illustration points out the very wide hemline tapering up to a slim waist with a simple bolero worn over a sleeveless blouse. The wide brim hat shaded the eyes and kept the hair in place. One can use their imagination and picture the accompanying figured hat and blouse with a matching pair of beach pajamas. Quite typical.

The multi-flowered ensemble with a matching jacket is fashioned in silk and features a self belt. This particular outfit could find its way to the beach or cross over into the lounging category.



Accompanying the above mentioned fashions one can also consider the dark glasses that came into their own during the late 20's. They appeared in many styles and colors. Most popular were the tortoise rimmed with either a yellow or haze tinted lens.

To complete the beach scene, one can imagine a paper parasol. Most likely with an oriental motif or brightly colored flowers. The handle and ribs will be wooden and have a short bottom end.



The Model A Clutch

Clutch Lining

Grease on the clutch lining is almost impossible to get out, there really isn't a good cleaner available to remove it. If grease becomes badly embedded, it is most advisable to replace the lining. A short term, emergency cure is to plug the opening in the bottom of the housing and pour in a gallon of hot water and detergent; idle the engine for two minutes with the clutch disengaged and then drain.

Clutch Chatter

If grease is allowed to get on the friction facings of the clutch it will begin to chatter during engagement and sometimes slip at high speeds. To remedy this, remove the clutch and install a new set of clutch disc facings. Also check the rear motor mounts for looseness if the clutch chatters. Motor mounts should be uniformly tight.

Clutch Wear

Two indications of clutch wear are: Engine races, but the car does not pick up speed and the clutch pedal adjustment has been used up. Premature clutch wear may be due to: Riding the clutch, lack of pedal travel clearance, racing the engine, and slipping the clutch when starting.

Pedal Movement

The correct free-play for the clutch pedal is approximately $\frac{3}{4}$ " for the early multiple disc clutch and one inch for the single disc clutch. This is the movement which takes place before the pedal starts to disengage the clutch. (See page 464 in the Service Bulletins.)

Adjusting the Clutch Pedal

The clutch pedal clearance can be adjusted by tightening or loosening the release arm rod. This is accomplished by removing the cotter pin from the clevis pin, then removing the clevis pin; this allows the adjusting rod to be turned. Turning the rod OUT increases the movement of the clutch pedal, screwing the rod IN decreases the movement. (See page 218 in the Service Bulletins.)

Steve Owsley

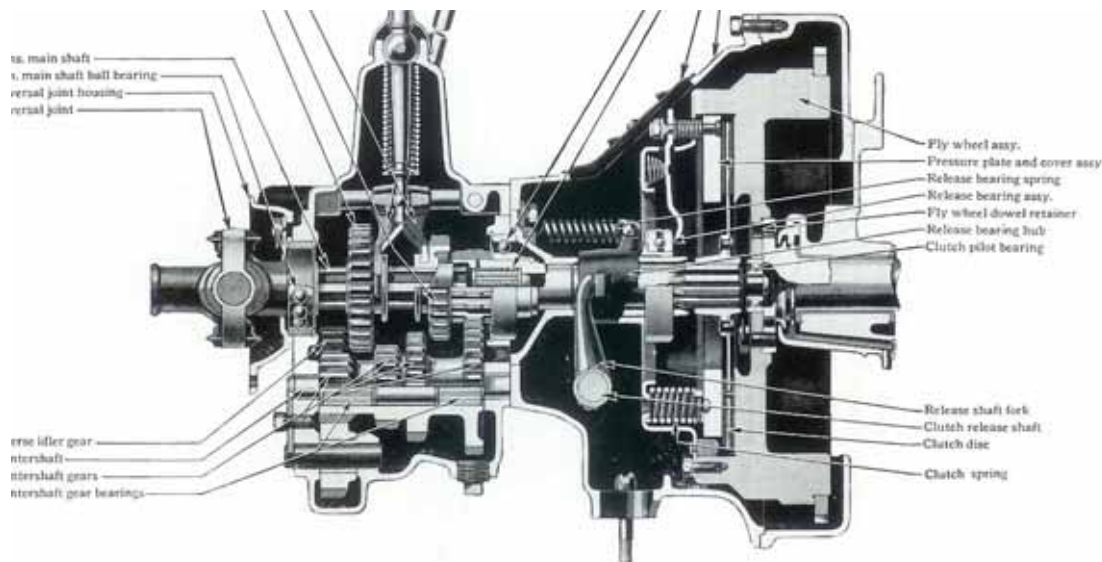

Model A Transmission and Clutch Assembly

2016 SAN FRANCISCO BAY AREA MAFCA TOURS

It's THE JOURNEY! NOT THE DESTINATION!

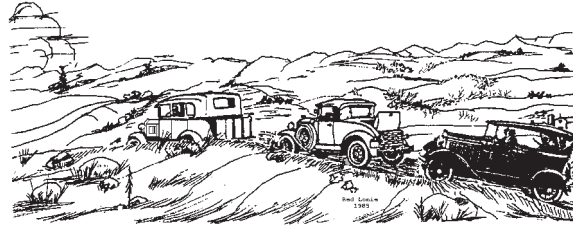

MONTH	DAY	TOUR LEADER	TOUR
JAN	31	BARRY KINNEY	PRESIDENT'S BRUNCH - BASQUE CULTURAL CTR.
FEB	20 SATURDAY	SF MODEL A FORD CLUB	CRAB FEED - MONTE CRISTO CLUB
MARCH	12 SATURDAY	BARRY KINNEY	ST. PATRICK'S DAY PARADE - SF
MARCH	16-21	BARRY KINNEY	LOS ANGELES MUSEUM TOUR
APRIL	23	KINNEY	SPRING SPEED WEEKEND - AUBURN, CA
APRIL	24	SF MODEL A FORD CLUB	DREAM MACHINES - HALF MOON BAY
MAY	30 MONDAY	CAPLAN	MEMORIAL DAY OBSERVANCE - PRESIDIO
JUNE	18 SATURDAY	CAPLAN / OWSLEY	ST. ANNE'S HOME - FATHER'S DAY WEEKEND
JUNE	26	CAPLAN / OWSLEY	PRIDE PARADE - SAN FRANCISCO
AUG	14	KINNEY	BARRY'S MAGICAL MYSTERY TOUR
SEPT	11 SUNDAY	KINNEY	ANTIQUE AUTOS HISTORY PARK - SAN JOSE
SEPT	17 SATURDAY	MAHL	41 ST ANNUAL 28 TH AVENUE BLOCK PARTY
SEPT	23-25	CAPLAN / OWSLEY / MACHADO	OVERNIGHTER MURPHYS-IRONSTONE CONCOURS
OCT	9	BARRANGO	COLUMBUS DAY PARADE - NORTH BEACH, SF
OCT	TBA	CAPLAN / OWSLEY	SF OLD CAR PICNIC - GOLDEN GATE PARK
Nov	13	CAPLAN / KINNEY	VETERANS DAY PARADE - FISHERMAN'S WHARF
DEC	3 SATURDAY	CAPLAN / KINNEY	SFPD BRAVE THE BAY - AQUATIC PARK
DEC	10 SATURDAY	SF MODEL A CLUB	CHRISTMAS BANQUET - VAL'S - DALY CITY

If you would like to lead a tour, please call **Gary Barrango** at **415-821-2628**
We encourage Club Members to plan additional **driving tours** throughout the year.
There is room for more than one activity or tour per month.

2016 Schedule of Events

Jan 30	Turlock Swap Meet
Feb 20	SF Model A Club Annual Crab Feed
May 27-29	NCRG Roundup Modesto hosted by the Modesto A's - www.ncrgmafca.com
June 19-24	MAFCA National Convention, Loveland, CO, hosted by Model A Ford Club of Colorado
Dec 5-8	MAFCA National Awards Banquet, Reno NV, hosted by the Sagebrush Chapter

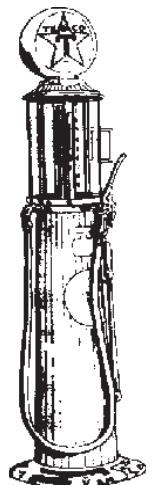

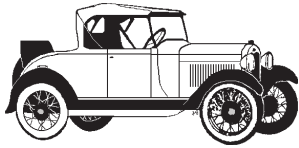

San Francisco Bay Area Chapter
Model A Ford Club of America
July 14, 2016

The meeting was called to order at 7:30 pm by President Barry Kinney. The minutes from the previous meeting were approved as written. There were no guests.

Reports of Officers

President: Barry's Mystery Tour will be on Sunday August 14. More details will come later. ♦ Ironstone Concours - all six rooms in Murphys have already been reserved. ♦ Pride Parade recap - Will be reported on next meeting. ♦ The Oil Museum in Taft the group that toured Los Angeles drove past, but could not visit because it was closed, is pictured on the cover of the current Restorer Magazine.

Vice President: Gunard met a Swedish couple in San Francisco and gave them a tour of the City in the Model A he bought from Tony Hobbs. They saw whales in the bay.

Secretary: No report

Treasurer: Jeanine received a thank you letter from St. Anne's Home. The 27th Avenue block party will be Saturday September 17. ♦ Jeanine brought up a question about the cost of entering our cars in the Pride Parade. She does not feel that we should have to pay. Walter indicated that this was the second time we had to pay. It was decided that we will get board approval to spend the money next year.

Editor: Walter reported on the train/automobile tour to the midwest in September of next year. He and Barry presented the proposed dates and places we plan to tour. It will be from September 5 - 18, 2017. We will discuss it at length in the next two months. ♦ Walter also talked about a tour Chris Thompson has planned. It will be Saturday July 23. Meet at Chris's shop in Richmond at 9 am. It will be a tour of the Red Oak Victory Ship, a car collection, and an ice cream social. Let Walter know if you want to attend.

Food and Beverage Chair: No report

Tour Chair: No report

For The Good Of The Order: No report

There was no entertainment.

Joan Peterson provided refreshments for the meeting. Jeanine Mahl will provide refreshments for the next meeting. There was no further business and the meeting was adjourned at 8:15 pm.

Respectfully submitted by

Joan Peterson, Secretary

SF Model A Club Monthly Meetings:

The meetings continue to be held monthly, the second Thursday of each month at 7:30 pm.

The location is the Monte Cristo Club at 136 Missouri Street in San Francisco.

The meeting place is located in a safe neighborhood and parking is convenient.

If you have questions or need directions, call Gary at (415) 821-2628 (daytime)

The next scheduled meeting will be on Thursday, August 11, 2016

A number of club members gather together for dinner before the monthly meeting at 6 pm.

Please feel free to join us – dinner location will be at Goat Hill Pizza at 18th & Connecticut.

The Choke Rod
is available online in color at
www.sfmodelaclub.org



in this
Choke Rod

President's Messagepage 2
Club Newspage 3
Fashionpage 4
Techpage 5
Tours & Schedule of Eventspage 6
Meeting Minutes.....page 7



www.sfmodelaclub.org

San Francisco Bay Area Chapter
Model A Ford Club of America
PO Box 31387
San Francisco, CA 94131-0387
415-621-0500

AUGUST MEETING
Thursday August 11, 2016
7:30 pm - Monte Cristo Club
136 Missouri Street (Potrero Hill)
San Francisco